

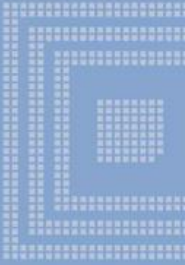

ASE GROUP



ASE Inc.

Q4 2014

Earnings Release

Presented by

Tien Wu
Chief Operating Officer

February 6, 2015



Safe Harbor Notice

This presentation contains "forward-looking statements" within the meaning of Section 27A of the United States Securities Act of 1933, as amended, and Section 21E of the United States Securities Exchange Act of 1934, as amended, including statements regarding our future results of operations and business prospects. Although these forward-looking statements, which may include statements regarding our future results of operations, financial condition or business prospects, are based on our own information and information from other sources we believe to be reliable, you should not place undue reliance on these forward-looking statements, which apply only as of the date of this press release. The words "anticipate," "believe," "estimate," "expect," "intend," "plan" and similar expressions, as they relate to us, are intended to identify these forward-looking statements in this press release. Our actual results of operations, financial condition or business prospects may differ materially from those expressed or implied in these forward-looking statements for a variety of reasons, including risks associated with cyclicity and market conditions in the semiconductor or electronic industry; changes in our regulatory environment, including our ability to comply with new or stricter environmental regulations and to resolve environmental liabilities; demand for the outsourced semiconductor packaging, testing and electronic manufacturing services we offer and for such outsourced services generally; the highly competitive semiconductor or manufacturing industry we are involved in; our ability to introduce new technologies in order to remain competitive; international business activities; our business strategy; our future expansion plans and capital expenditures; the strained relationship between the Republic of China and the People's Republic of China; general economic and political conditions; the recent global economic crisis; possible disruptions in commercial activities caused by natural or human-induced disasters; fluctuations in foreign currency exchange rates; and other factors. For a discussion of these risks and other factors, please see the documents we file from time to time with the Securities and Exchange Commission, including our 2013 Annual Report on Form 20-F filed on April 17, 2014.



Semiconductor Industry Growth Trend vs ASE Group Track Record

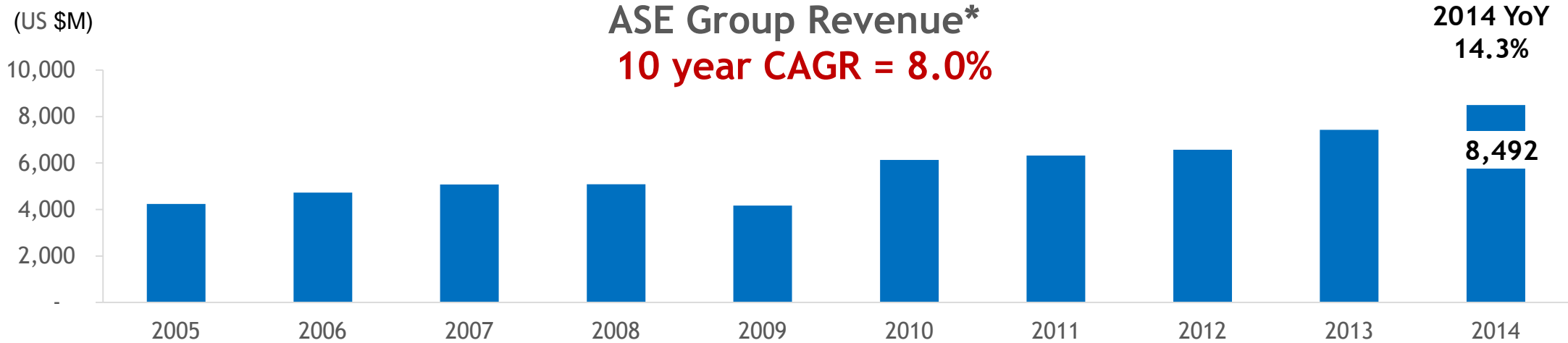
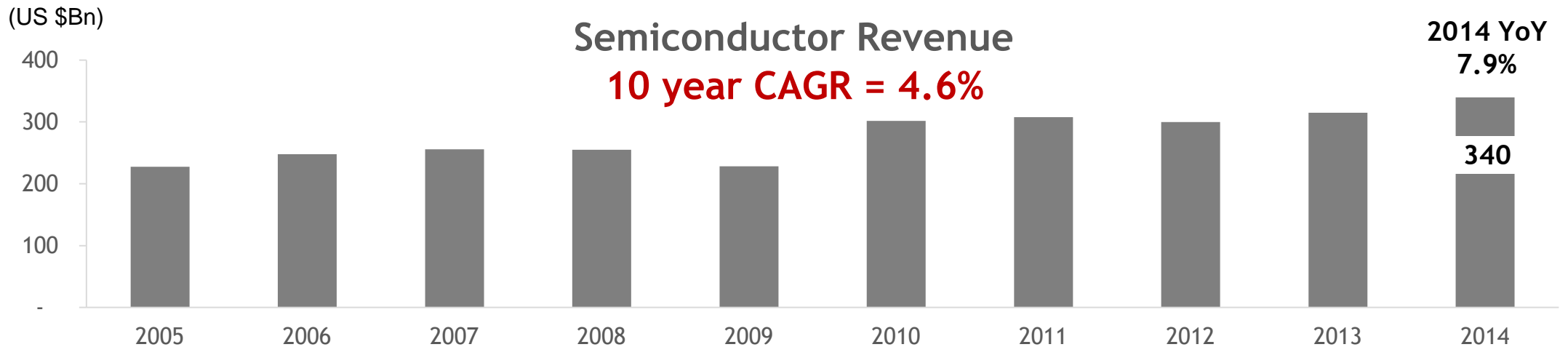

ASE Group Track Record

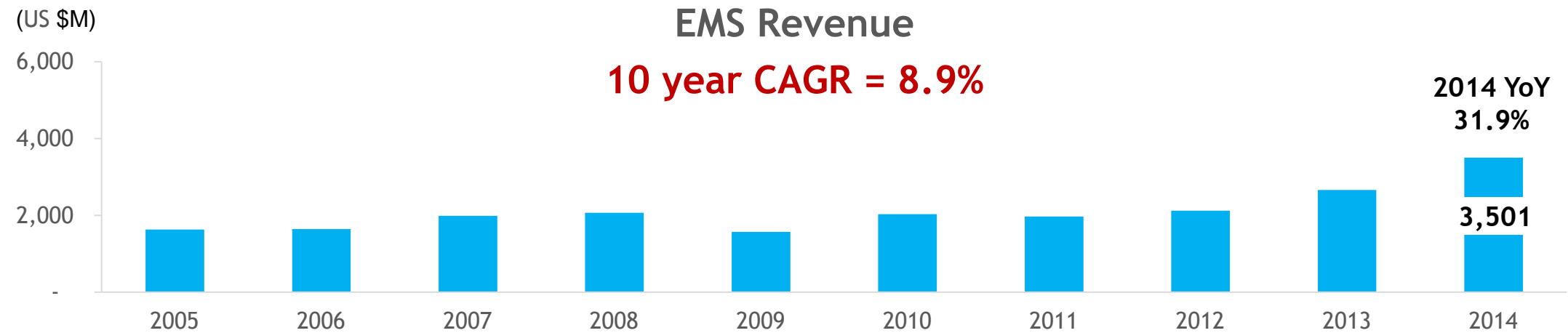
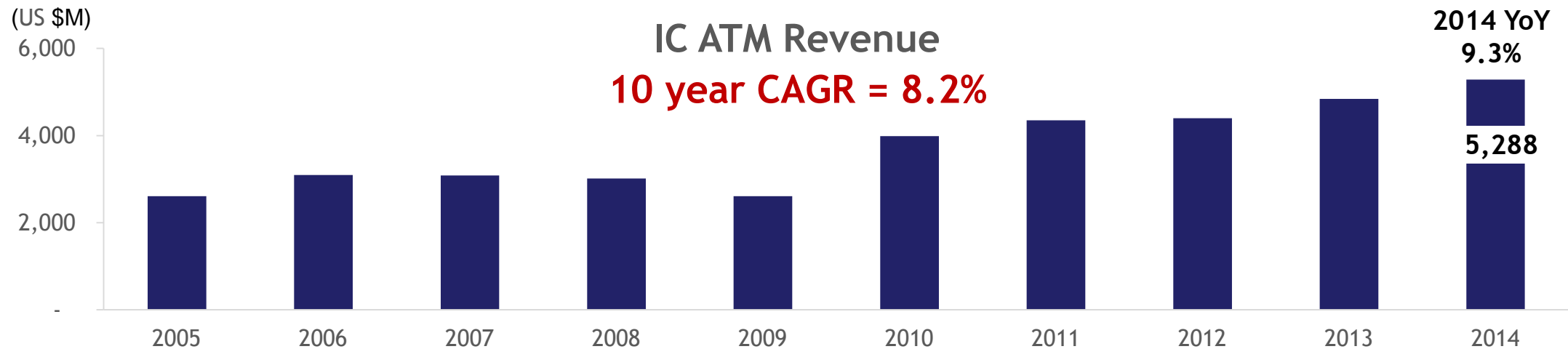

ASE Group Track Record

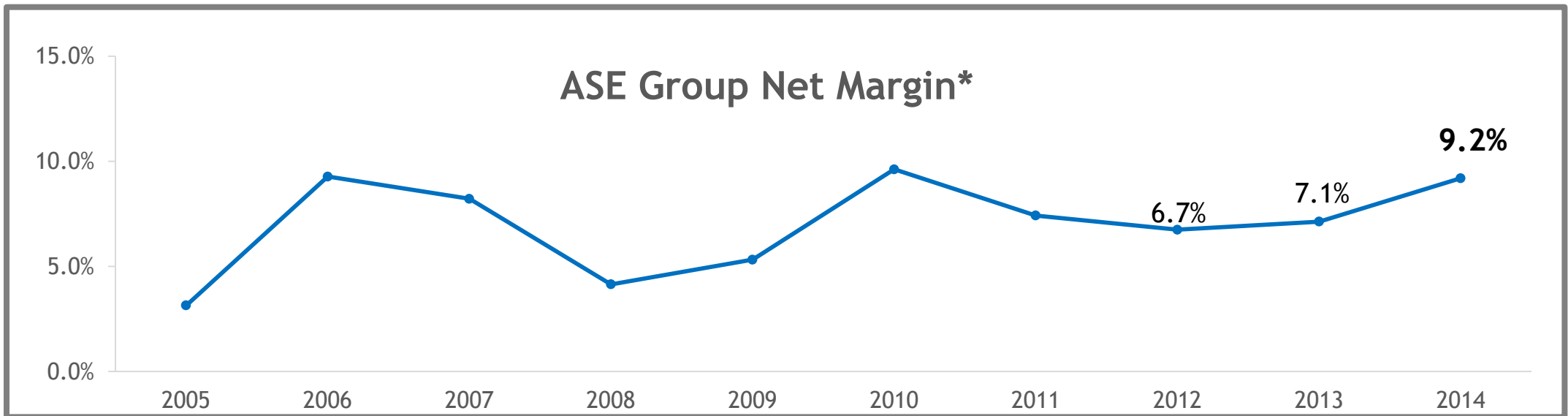
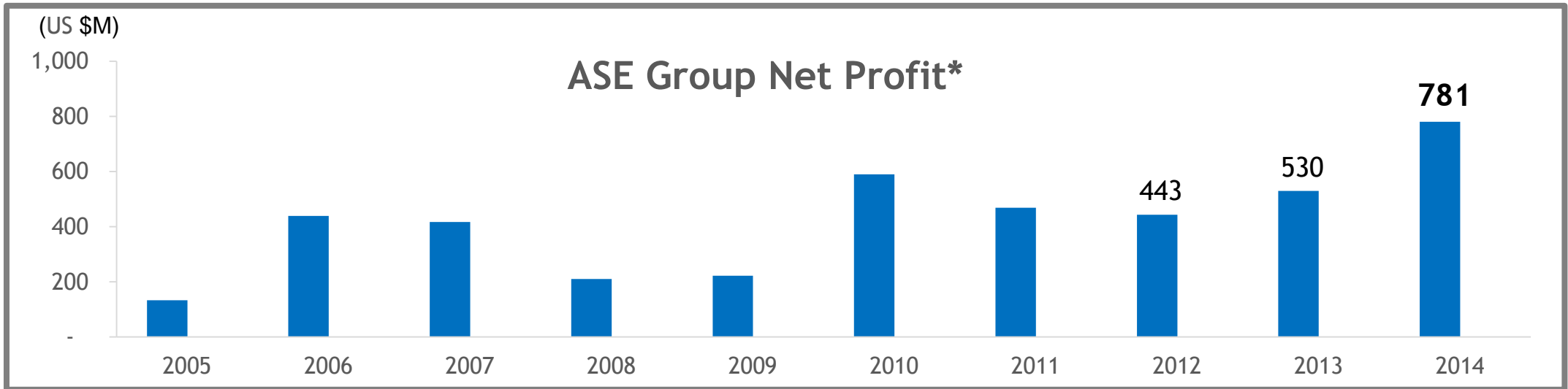

Industry CapEx Discipline & Consolidation



US\$M

Semiconductor Assembly & Test Equipment Sales Revenue

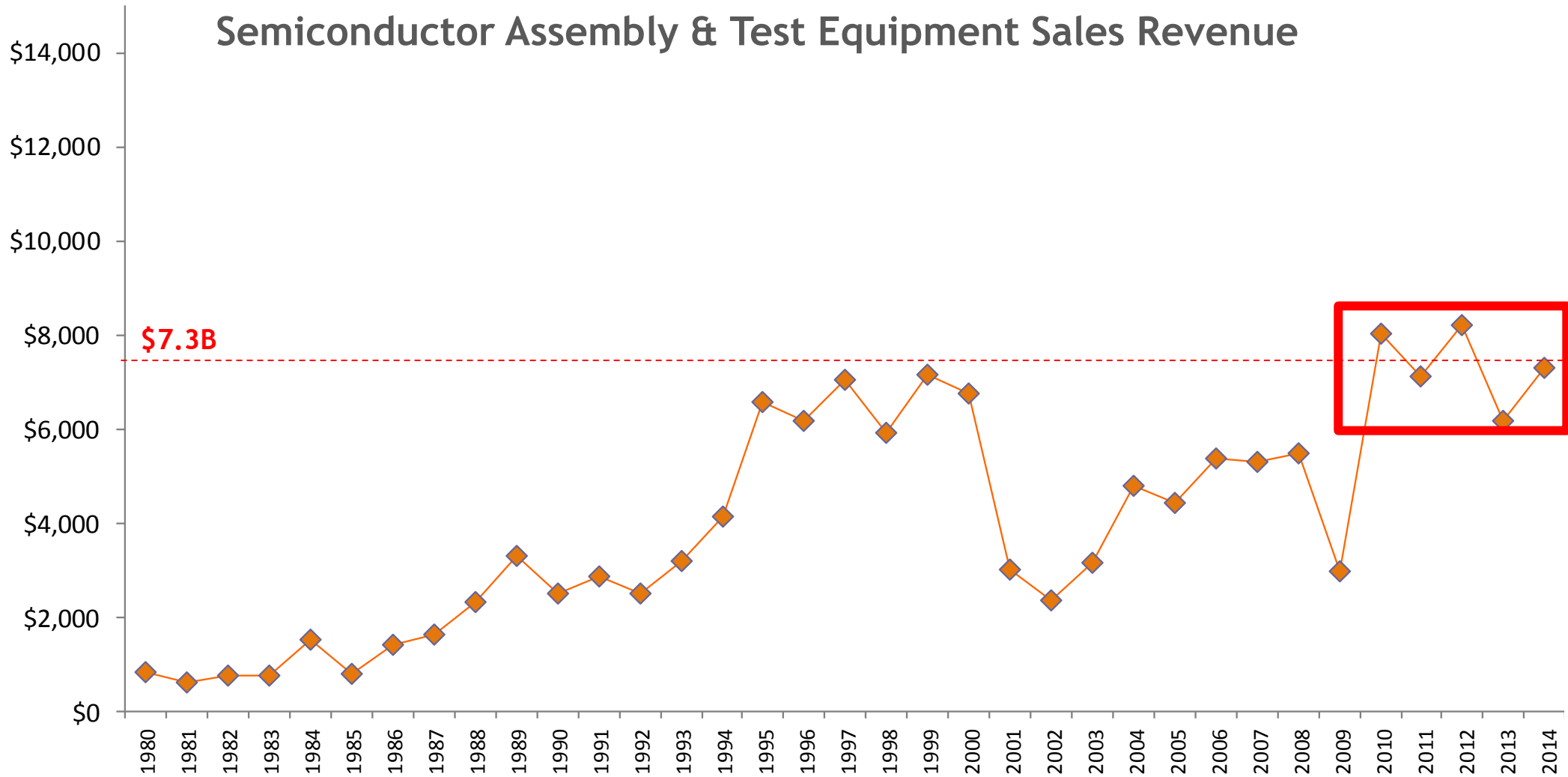

Source: Gartner Dataquest 2014/SEMI 2014/SIA 2014

ASE IC ATM Machinery CapEx

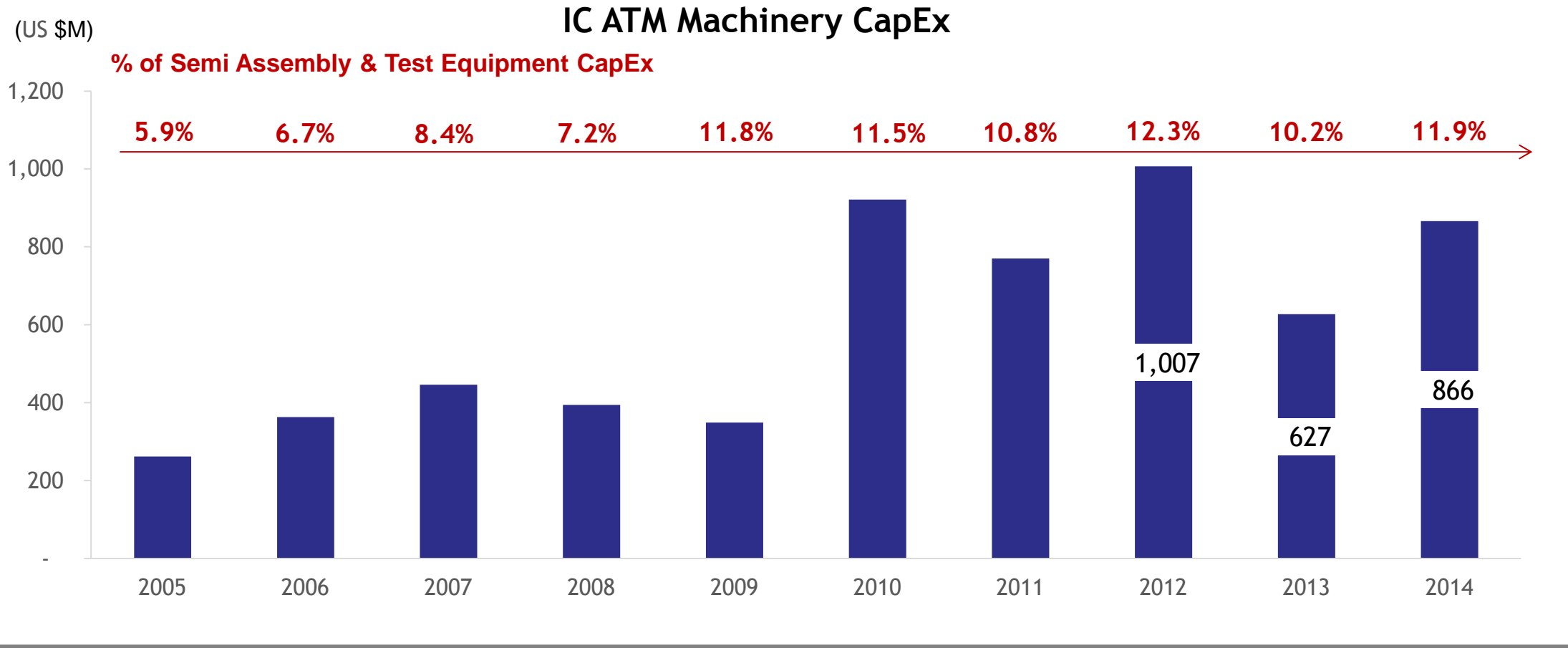

2014 Business Recap



- **Continued double-digit growth in Advanced Packaging**
 - 16% YoY revenue growth in 2014
 - Growth driven by SiP
- **Sustained Copper Wire Bonding leadership**
 - 15% YoY revenue growth in 2014
 - Share gain, Copper conversion ramp in new markets such as automotive
- **Enhanced technology building blocks for system integration**
 - Flip Chip Cu Pillar, Wafer Level Packaging + Fanout, 2.5D Silicon Interposer, Embedded technology

Note: Sequential revenue growth rates are based on US dollar revenue

Advanced Packaging: Leading Growth



ASE GROUP

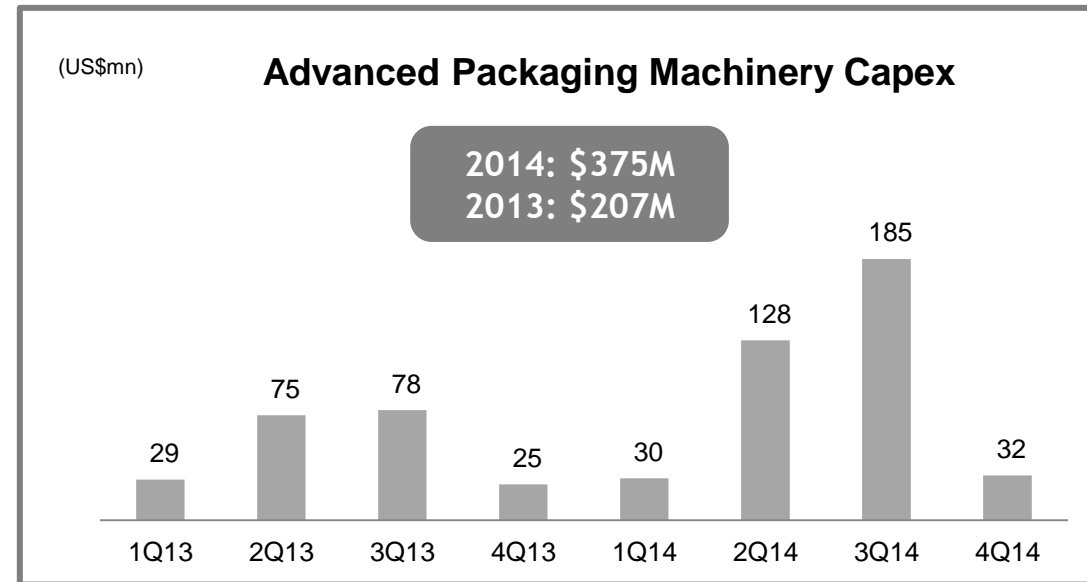
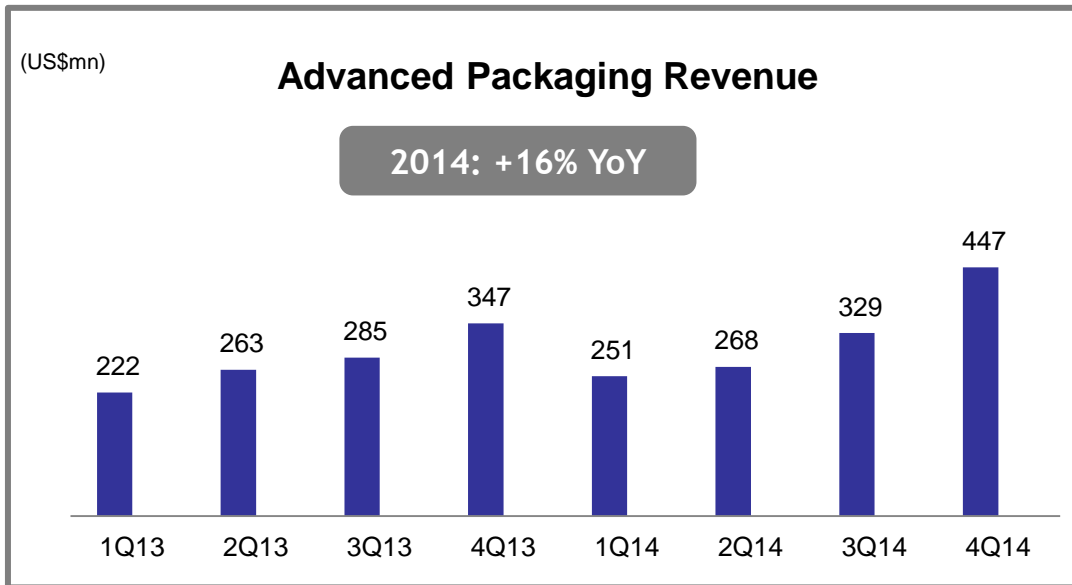

Note: (1) Advanced Packaging Revenue & Capex include Flip Chip Packaging, Bumping/Wafer Level Packaging and SiP. (2) Advanced Packaging Revenue is based on IC ATM level result. (3) Capex is for machinery only. (4) Sequential revenue growth is based on US dollar revenue.

- 2015 growth trend should continue



Copper Wire Bonding: IDM Penetration

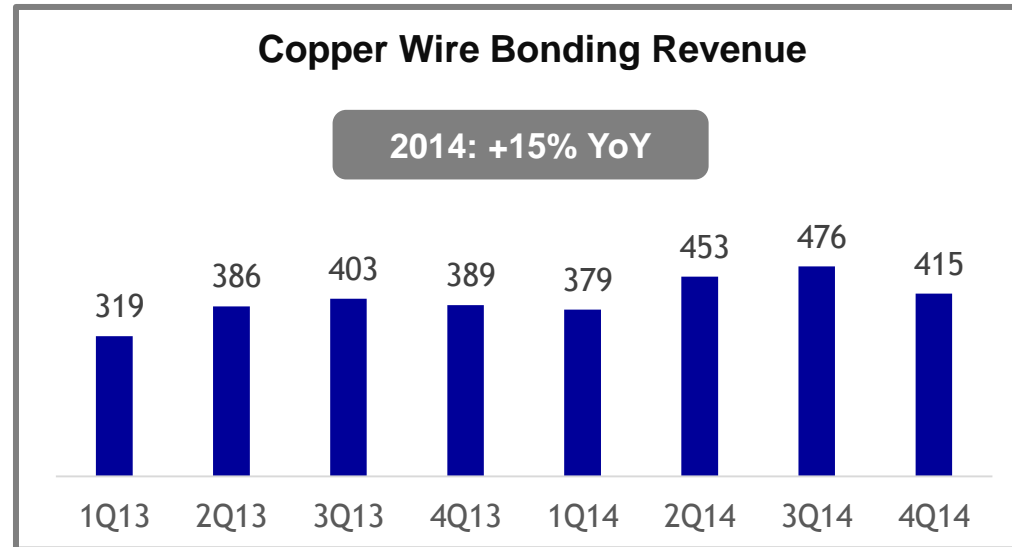

Note: Sequential revenue growth is based on US dollar revenue

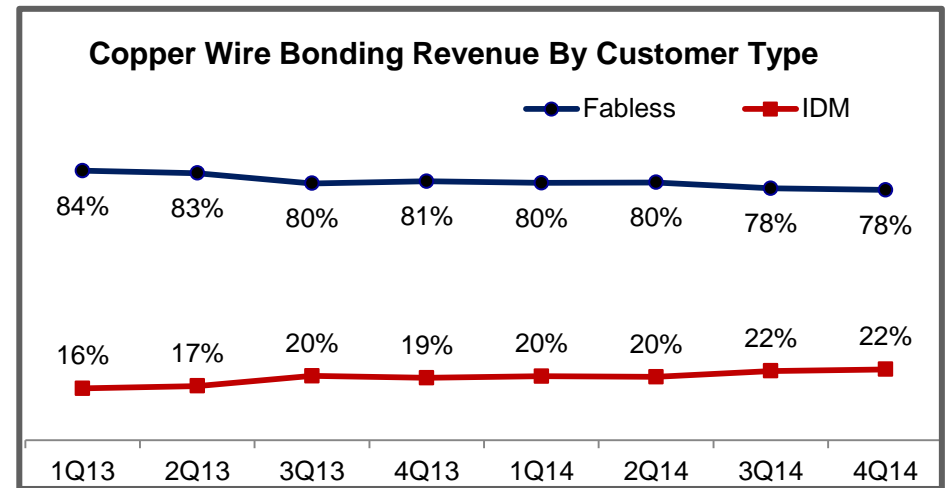
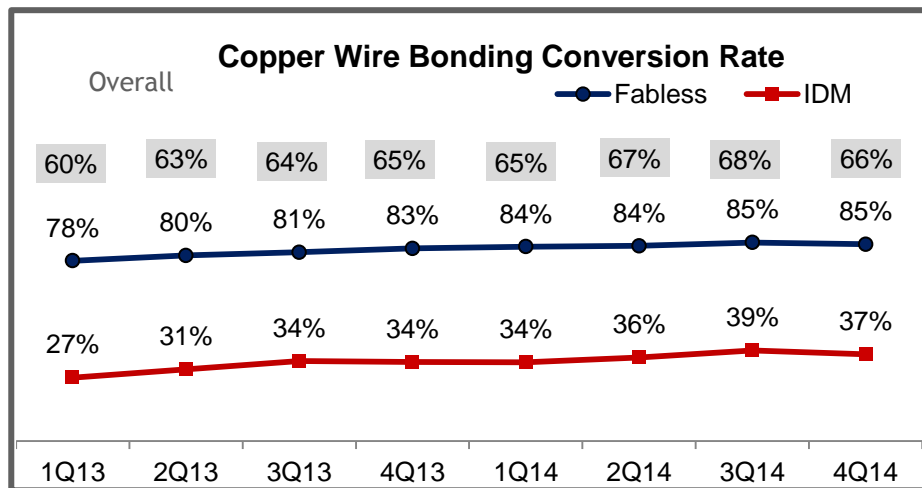

Note: Copper Wire Bonding conversion rate is defined as copper wire bonding revenue as % of total IC wire bonding revenue

Driving EMS Growth via SiP Technology



IC ATM and EMS Collaboration



- Consolidated SiP revenue accounted for 18% of ASE Group revenue in 4Q14

SiP Solutions for the Next Wave

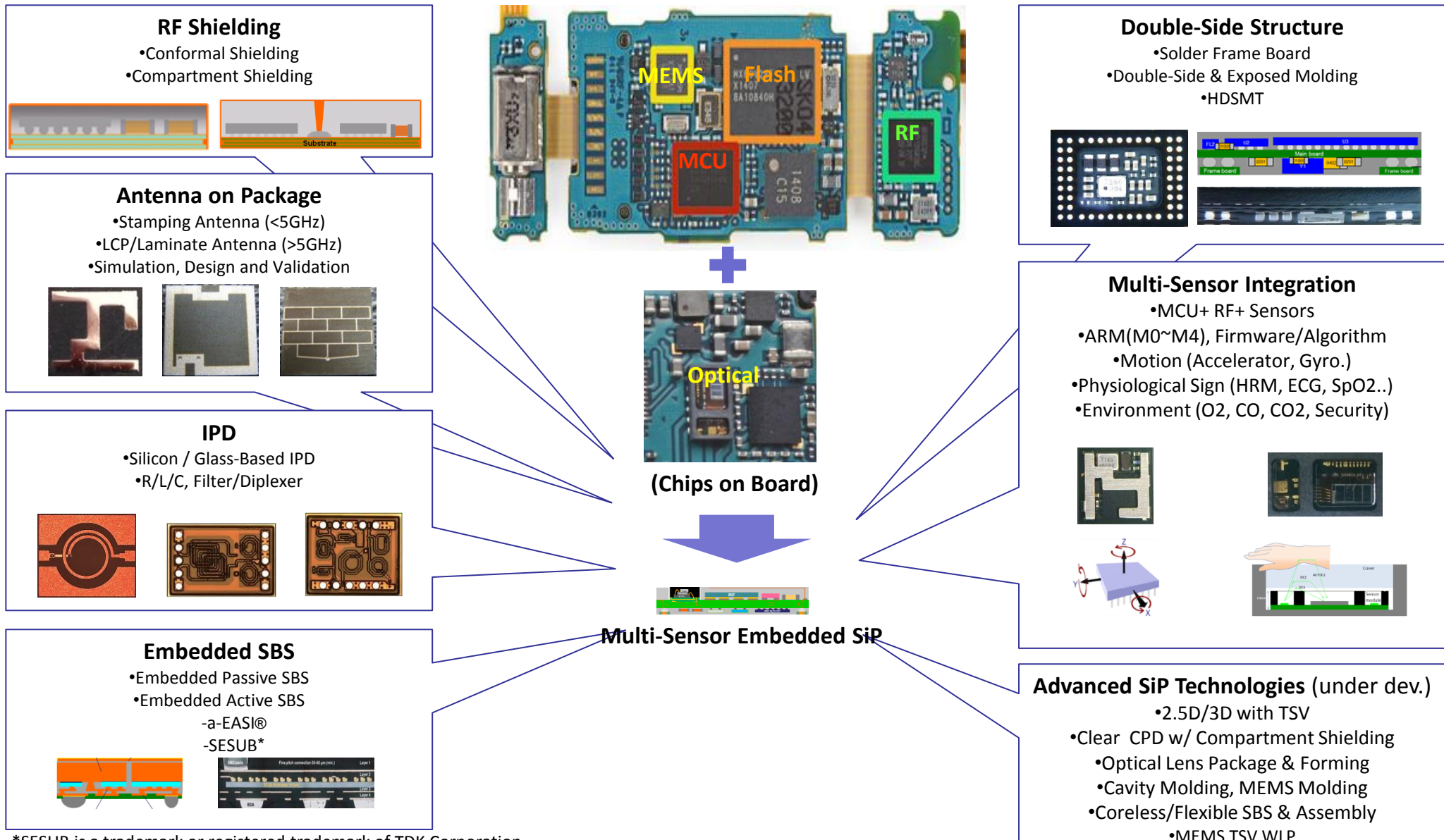

*SESUB is a trademark or registered trademark of TDK Corporation

Outlook for 2015

- **Continue growth pattern**
 - Market share gain
 - System integration
- **Maintain CapEx discipline and operational efficiency**
- **Leadership in Advanced Packaging and SiP**
 - Launch & ramp new EMS SiP projects

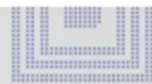

Thank You

www.aseglobal.com

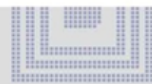



ASE GROUP

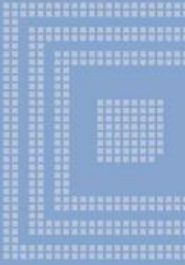

ASE Inc. 2014 Fourth Quarter Earnings Release

Joseph Tung
Chief Financial Officer
ASE Inc.
Feb. 6, 2015

Safe Harbor Notice



This presentation contains "forward-looking statements" within the meaning of Section 27A of the United States Securities Act of 1933, as amended, and Section 21E of the United States Securities Exchange Act of 1934, as amended, including statements regarding our future results of operations and business prospects. Although these forward-looking statements, which may include statements regarding our future results of operations, financial condition or business prospects, are based on our own information and information from other sources we believe to be reliable, you should not place undue reliance on these forward-looking statements, which apply only as of the date of this press release. The words "anticipate," "believe," "estimate," "expect," "intend," "plan" and similar expressions, as they relate to us, are intended to identify these forward-looking statements in this press release. Our actual results of operations, financial condition or business prospects may differ materially from those expressed or implied in these forward-looking statements for a variety of reasons, including risks associated with cyclicity and market conditions in the semiconductor or electronic industry; changes in our regulatory environment, including our ability to comply with new or stricter environmental regulations and to resolve environmental liabilities; demand for the outsourced semiconductor packaging, testing and electronic manufacturing services we offer and for such outsourced services generally; the highly competitive semiconductor or manufacturing industry we are involved in; our ability to introduce new technologies in order to remain competitive; international business activities; our business strategy; our future expansion plans and capital expenditures; the strained relationship between the Republic of China and the People's Republic of China; general economic and political conditions; the recent global economic crisis; possible disruptions in commercial activities caused by natural or human-induced disasters; fluctuations in foreign currency exchange rates; and other factors. For a discussion of these risks and other factors, please see the documents we file from time to time with the Securities and Exchange Commission, including our 2013 Annual Report on Form 20-F filed on April 17, 2014.



Consolidated Statements of Comprehensive Income

Quarterly Sequential Comparison

(unaudited)



(NT\$ Million)	Q4 / 2014	%	Q3 / 2014	%	Change
Net Revenues:					
Packaging	31,942	41.7%	32,031	48.1%	0%
Testing	6,663	8.7%	6,827	10.2%	-2%
Direct Material	861	1.1%	1,033	1.6%	-17%
EMS	37,178	48.5%	26,741	40.1%	39%
Others	0	0.0%	0	0.0%	
Total Net Revenues	76,644	100.0%	66,632	100.0%	15%
Gross Profit	16,393	21.4%	14,198	21.3%	15%
Operating Income (Loss)	9,817	12.8%	8,084	12.1%	21%
Pretax Income (Loss)	9,550	12.5%	8,590	12.9%	11%
Income Tax Benefit (Expense)	(1,470)	-1.9%	(1,237)	-1.9%	
Noncontrolling Interest	(224)	-0.3%	(148)	-0.2%	
Net Income Attributable to Shareholders of the Parent	7,856	10.2%	7,205	10.8%	9%
Basic EPS (NT Dollar)	1.02		0.94		9%
Diluted EPS (NT Dollar)	0.99		0.82		21%
EBITDA	17,228	22.5%	15,865	23.8%	9%



Consolidated Statements of Comprehensive Income

Quarterly Year-over-Year Comparison

(unaudited)



(NT\$ Million)	Q4 / 2014	%	Q4 / 2013	%	Change
Net Revenues:					
Packaging	31,942	41.7%	28,703	44.7%	11%
Testing	6,663	8.7%	6,225	9.7%	7%
Direct Material	861	1.1%	746	1.2%	15%
EMS	37,178	48.5%	28,411	44.3%	31%
Others	0	0.0%	79	0.0%	
Total Net Revenues	76,644	100.0%	64,164	100.0%	19%
Gross Profit	16,393	21.4%	12,510	19.5%	31%
Operating Income (Loss)	9,817	12.8%	6,939	10.8%	41%
Pretax Income (Loss)	9,550	12.5%	5,792	9.0%	65%
Income Tax Benefit (Expense)	(1,470)	-1.9%	(450)	-0.7%	
Noncontrolling Interest	(224)	-0.3%	(134)	-0.2%	
Net Income Attributable to Shareholders of the Parent	7,856	10.2%	5,208	8.1%	51%
Basic EPS (NT Dollar)	1.02		0.68		50%
Diluted EPS (NT Dollar)	0.99		0.66		50%
EBITDA	17,228	22.5%	12,958	20.2%	33%



Consolidated Statements of Comprehensive Income

Full Year Comparison

(unaudited)



(NT\$ Million)	FY / 2014	%	FY / 2013	%	Change
Net Revenues:					
Packaging	121,336	47.3%	112,604	51.2%	8%
Testing	25,875	10.1%	24,732	11.2%	5%
Direct Material	3,546	1.4%	2,951	1.3%	20%
EMS	105,785	41.2%	78,531	35.7%	35%
Others	49	0.0%	1,044	0.4%	
Total Net Revenues	256,591	100.0%	219,862	100.0%	17%
Gross Profit	53,540	20.9%	42,814	19.5%	25%
Operating Income (Loss)	29,571	11.5%	22,044	10.0%	34%
Pretax Income (Loss)	28,474	11.1%	19,357	8.8%	47%
Income Tax Benefit (Expense)	(4,252)	-1.7%	(3,202)	-1.5%	
Noncontrolling Interest	(629)	-0.2%	(466)	-0.2%	
Net Income Attributable to Shareholders of the Parent	23,593	9.2%	15,689	7.1%	50%
Basic EPS (NT Dollar)	3.07		2.09		47%
Diluted EPS (NT Dollar)	2.95		2.03		45%
EBITDA	57,566	22.4%	47,721	21.7%	21%



IC ATM Statements of Comprehensive Income

Quarterly Sequential Comparison

(unaudited)



(NT\$ Million)	Q4 / 2014	%	Q3 / 2014	%	Change
Net Revenues:					
Packaging	36,359	82.9%	34,349	81.4%	6%
Testing	6,663	15.2%	6,827	16.2%	-2%
Direct Material	862	2.0%	1,035	2.5%	-17%
Total Net Revenues	43,884	100.0%	42,211	100.0%	4%
Gross Profit	13,754	31.3%	12,073	28.6%	14%
Operating Income (Loss)	8,905	20.3%	7,348	17.4%	21%
Pretax Income (Loss)	9,261	21.1%	8,366	19.8%	11%
Income Tax Benefit (Expense)	(1,340)	-3.1%	(1,105)	-2.6%	
Noncontrolling Interest	(65)	-0.1%	(56)	-0.1%	
Net Income Attributable to Shareholders of the Parent	7,856	17.9%	7,205	17.1%	9%
EBITDA	15,775	35.9%	14,748	34.9%	7%



IC ATM Statements of Comprehensive Income

Quarterly Year-over-Year Comparison

(unaudited)



(NT\$ Million)	Q4 / 2014	%	Q4 / 2013	%	Change
Net Revenues:					
Packaging	36,359	82.9%	30,929	81.6%	18%
Testing	6,663	15.2%	6,225	16.4%	7%
Direct Material	862	2.0%	746	2.0%	16%
Total Net Revenues	43,884	100.0%	37,900	100.0%	16%
Gross Profit	13,754	31.3%	10,448	27.6%	32%
Operating Income (Loss)	8,905	20.3%	6,149	16.2%	45%
Pretax Income (Loss)	9,261	21.1%	5,654	14.9%	64%
Income Tax Benefit (Expense)	(1,340)	-3.1%	(405)	-1.1%	
Noncontrolling Interest	(65)	-0.1%	(41)	-0.1%	
Net Income Attributable to Shareholders of the Parent	7,856	17.9%	5,208	13.7%	51%
EBITDA	15,775	35.9%	11,668	30.8%	35%



IC ATM Statements of Comprehensive Income

Full Year Comparison

(unaudited)



(NT\$ Million)	FY / 2014	%	FY / 2013	%	Change
Net Revenues:					
Packaging	130,287	81.6%	115,639	80.7%	13%
Testing	25,875	16.2%	24,732	17.3%	5%
Direct Material	3,550	2.2%	2,951	2.1%	20%
Total Net Revenues	159,712	100.0%	143,322	100.0%	11%
Gross Profit	44,658	28.0%	35,041	24.4%	27%
Operating Income (Loss)	26,436	16.6%	19,011	13.3%	39%
Pretax Income (Loss)	27,444	17.2%	18,397	12.8%	49%
Income Tax Benefit (Expense)	(3,662)	-2.3%	(2,547)	-1.8%	
Noncontrolling Interest	(189)	-0.1%	(161)	-0.1%	
Net Income Attributable to Shareholders of the Parent	23,593	14.8%	15,689	10.9%	50%
EBITDA	52,726	33.0%	42,744	29.8%	23%



Packaging Operations



NT\$ Million

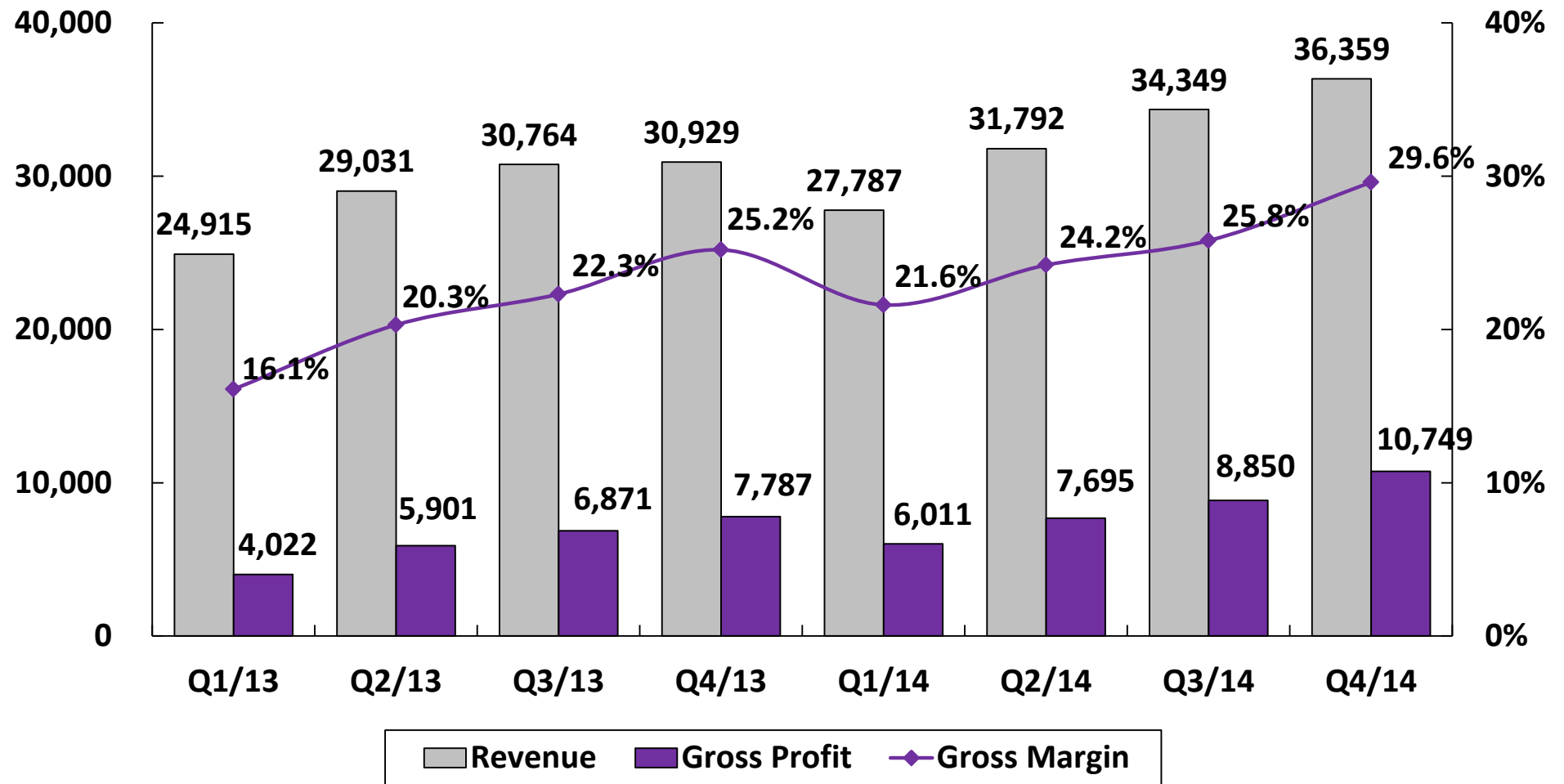

Packaging Operations

Package Revenue Breakdown

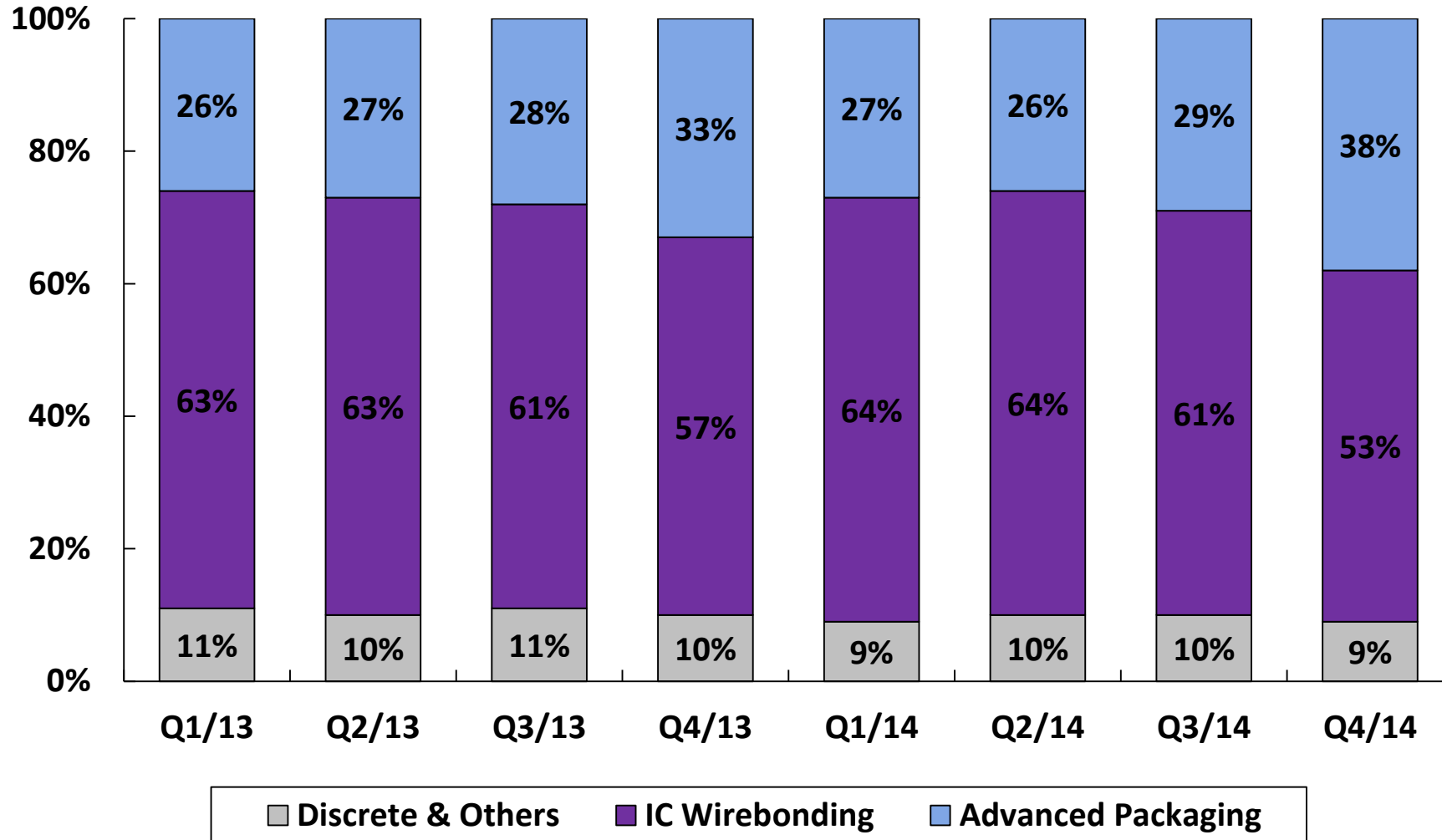

Testing Operations



NT\$ Million

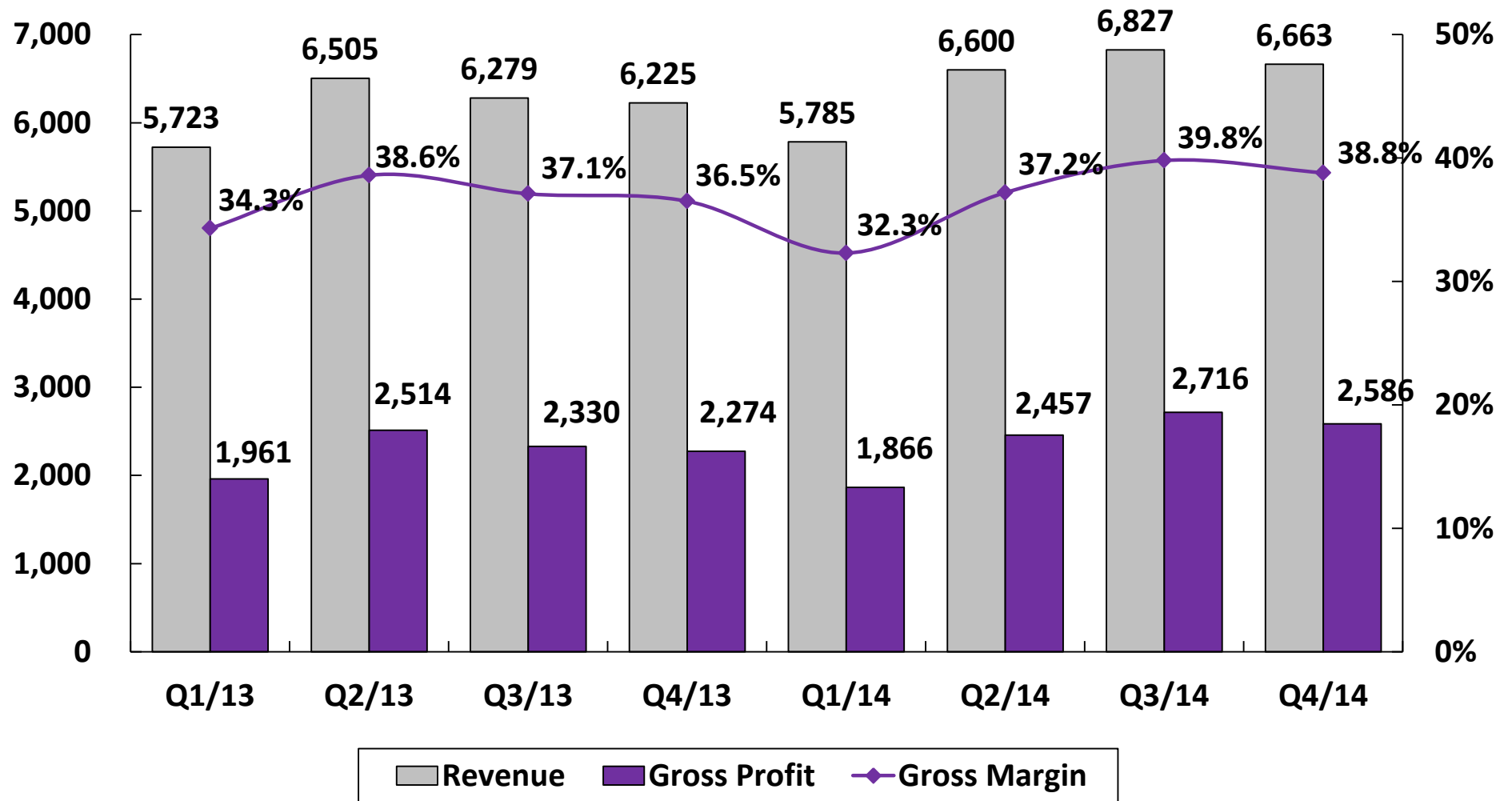

Material Operations



NT\$ Million

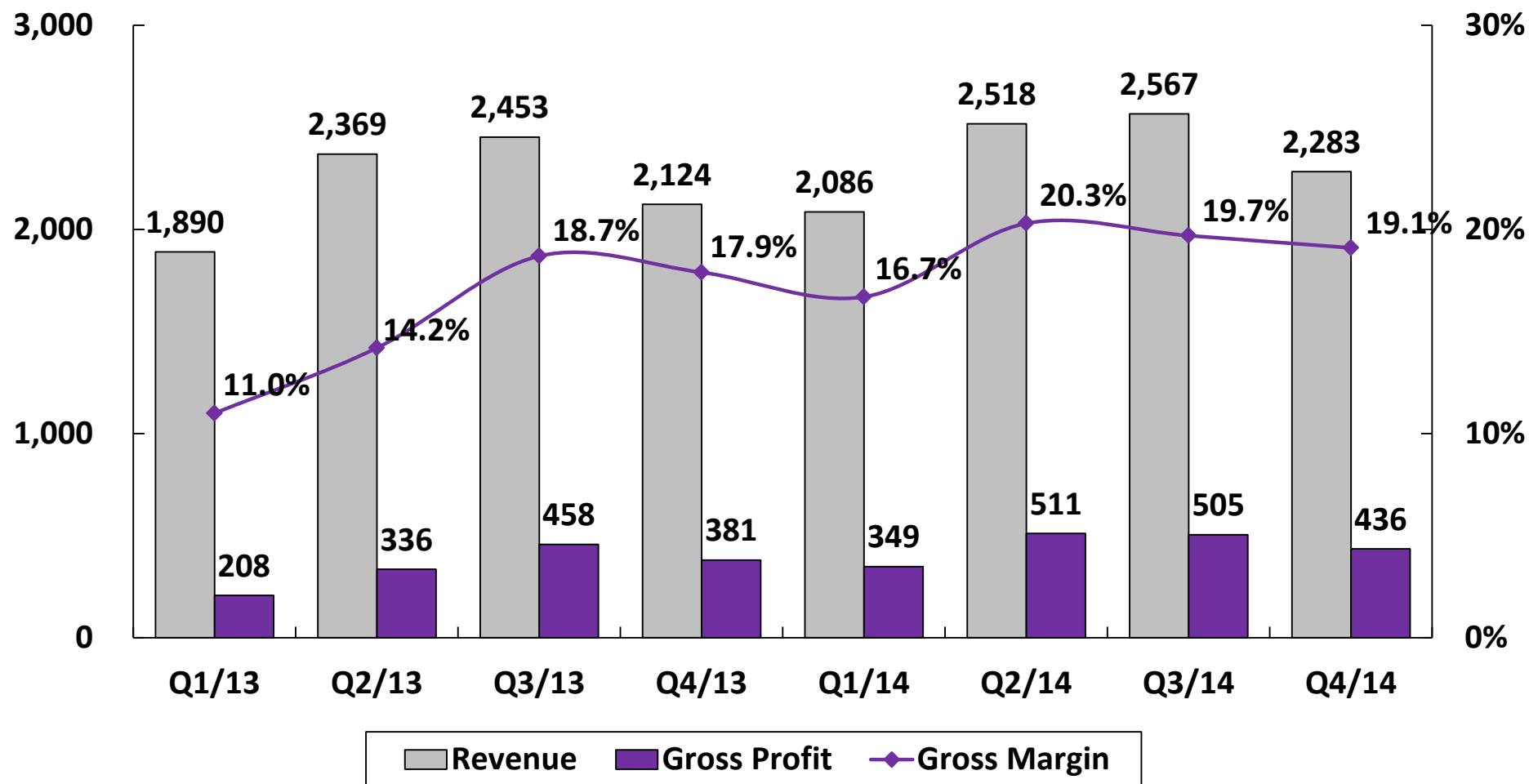

IC ATM Revenue by Application

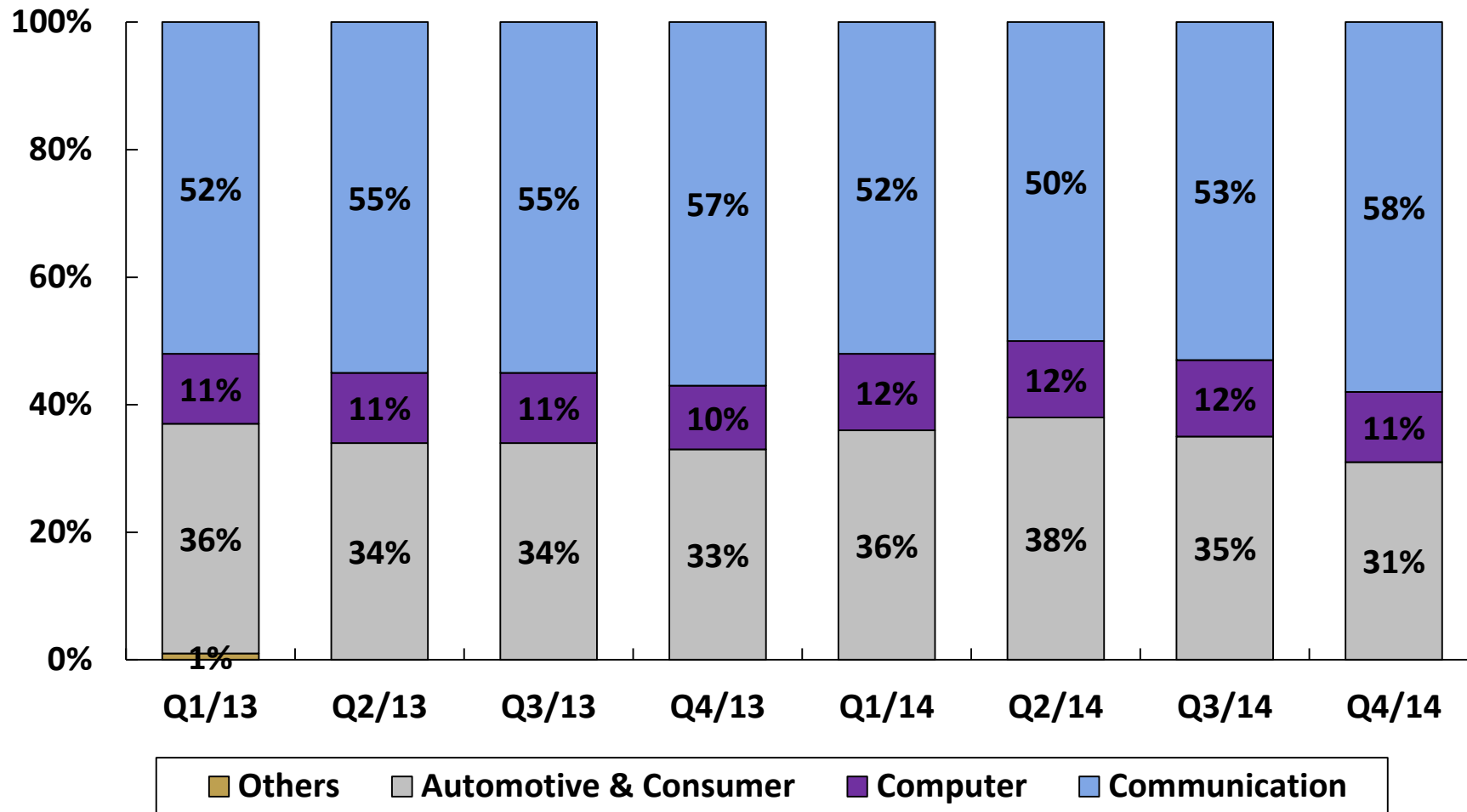

EMS Operations



NT\$ Million

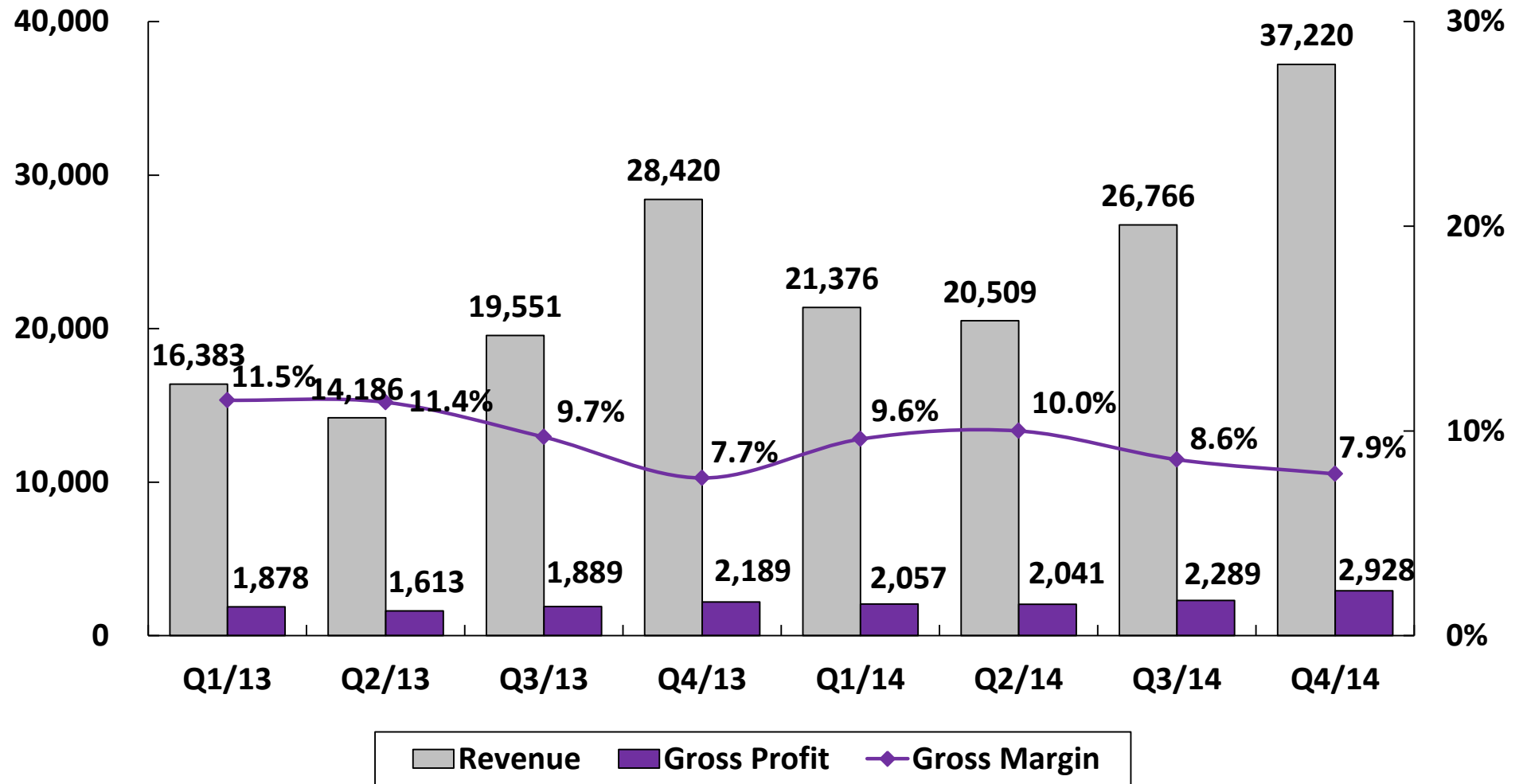

EMS Operations

EMS Revenue Breakdown

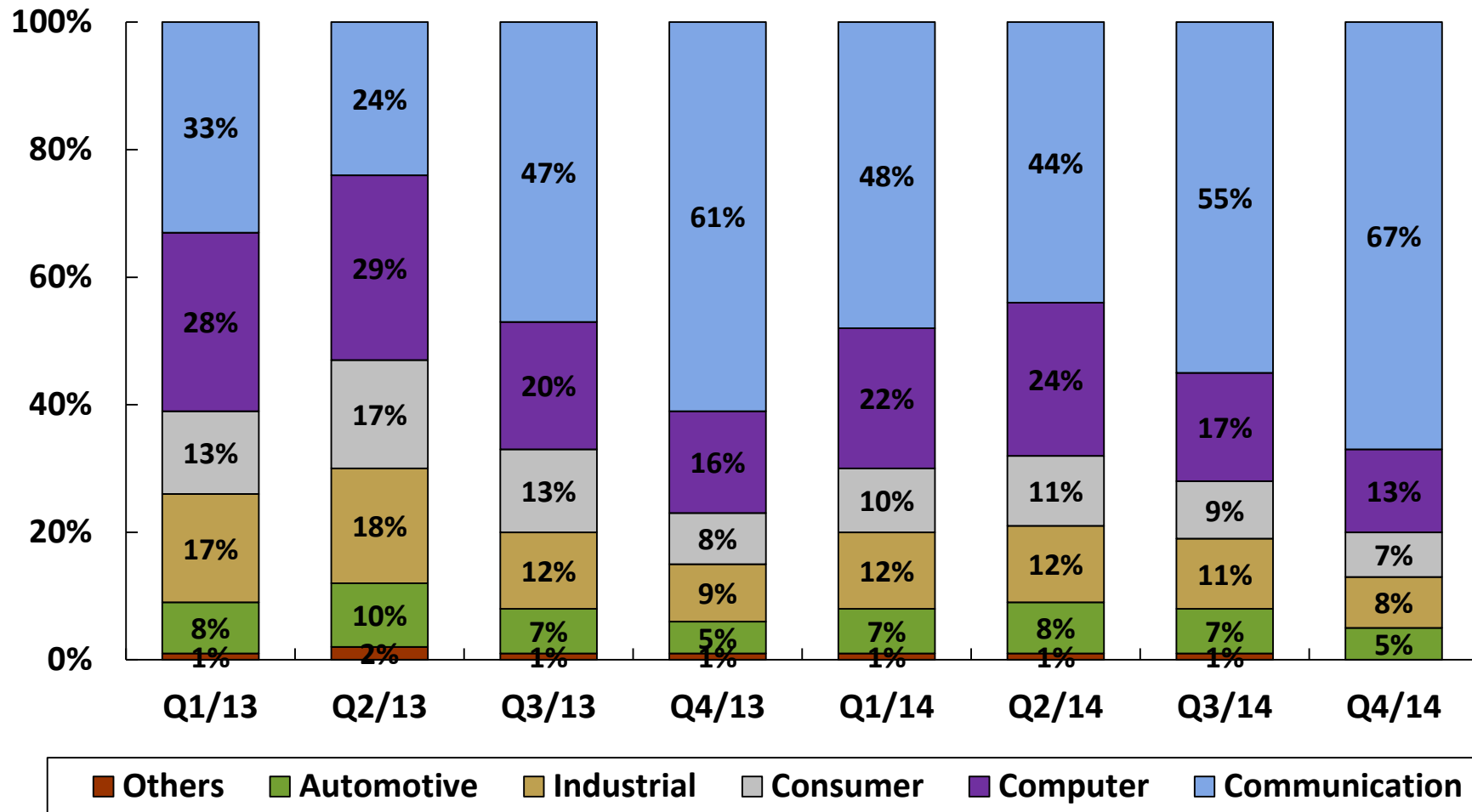

Key Balance Sheet Items & Indices

(unaudited)



(NT\$ Million)	Dec. 31, 2014	Sept. 30, 2014	Change
Cash and cash equivalent	51,694	32,968	56.8%
Financial assets - current	6,522	3,817	70.9%
Financial assets - non current & investments - equity method	2,434	2,475	-1.7%
Property, plant & equipment	151,587	148,998	1.7%
Total assets	333,971	304,727	9.6%
Short-term borrowings	41,176	38,672	6.5%
Current portion of long-term borrowings & capital lease obligations	2,835	3,226	-12.1%
Bonds payable	31,270	30,194	3.6%
Long-term borrowings & capital lease obligations	24,106	22,826	5.6%
Total equity (Including non-controlling interest)	158,436	136,111	16.4%
Quarterly EBITDA	17,228	15,865	8.6%
Current ratio	1.44	1.24	
Net debt to equity	0.26	0.43	



Machinery & Equipment Capital Expenditure vs. EBITDA



US\$ Million

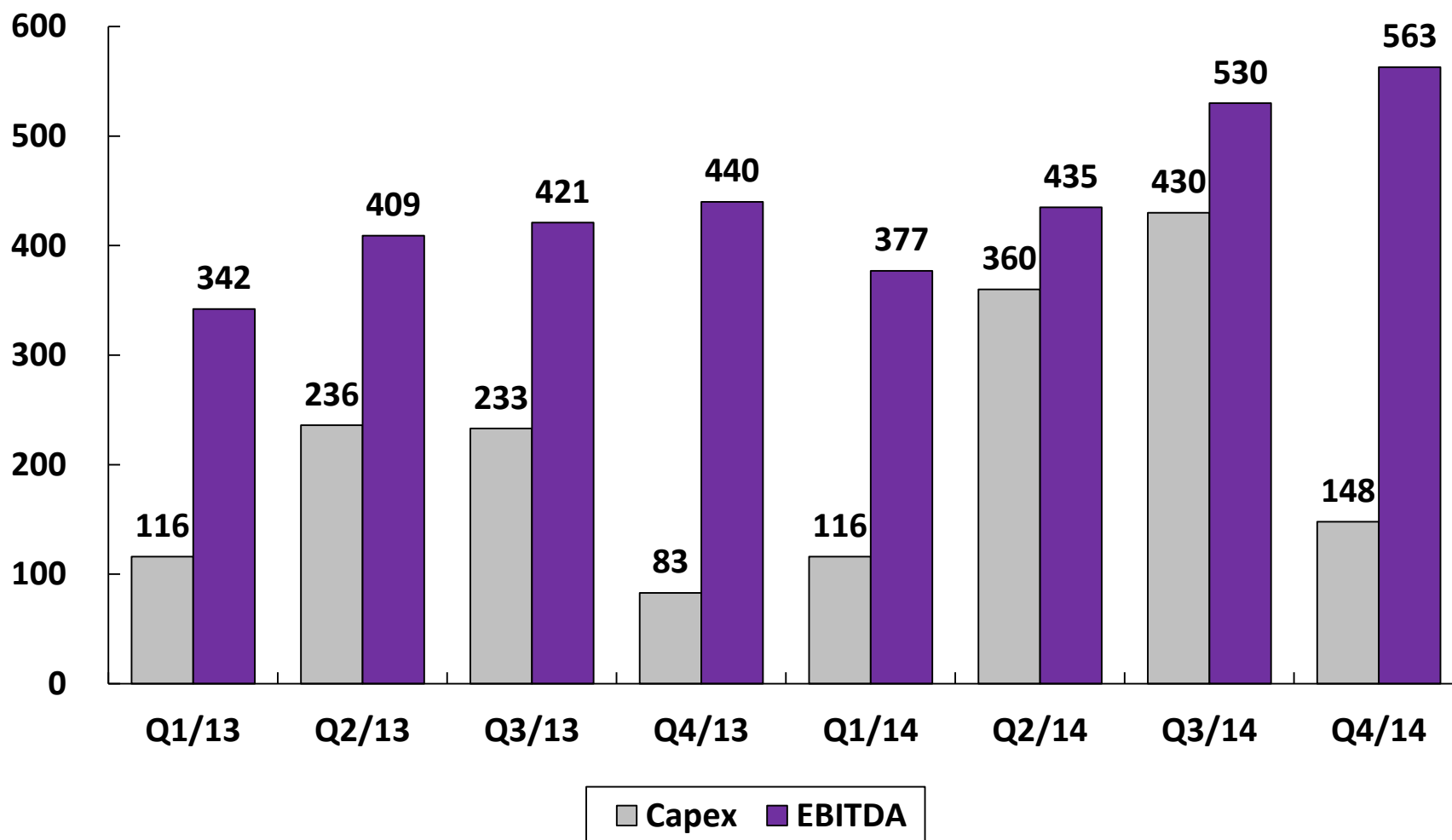

First Quarter 2015 Outlook



Based on our current business outlook and exchange rate assumptions, management projects overall performance for the first quarter of 2015 to be as follows:

- **IC ATM production capacity and blended ASP will be flat; blended IC ATM utilization will come down by 10-15%;**
- **The pace for our EMS Q1 sequential change should be similar to 2014Q1;**
- **Consolidated gross margin and operating margin should both be similar to 2014Q1.**



Thank You

www.aseglobal.com
ir@aseglobal.com

